

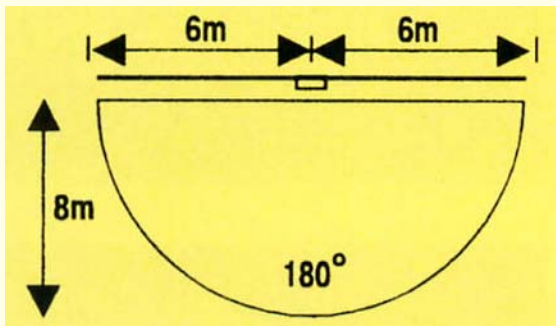

TECHNICAL DATA SHEET

PIR-002

PIR SENSOR (CAT 96VH180/150)



TECHNICAL SPECIFICATION

Electrical

Voltage Rating : 220 ~ 240V, 50Hz a.c.
Maximum Lighting Load : 150W Halogen lamp

Physical

Filed of view : 180 degree elliptical field
Sensor Range : 8 meter forward and 6 meter either side
Timer setting : 20 sec. to 10 min (light on period)
Protection : IP44
Operating Temperature : -5 °C ~ 35 °C

Description

PIR sensors provide a cost efficient form of security. The units advanced passive infrared component reacts instantly to changes in heat. Anyone entering the PIR field of view will instantly activate the lighting. Unwanted intruders will be frightened off by the sudden switching on of lights, giving you peace of mind. And when your home left unattended at night, this PIR sensors keep a constant vigil over your property.

When you or visitors arrive home at night, PIR sensors switch on automatically to light the way, giving a safe passage right to your door or through the house.

Features

- Advance Passive Infrared Technology reacts instantly to changes in heat
- Flexibility in timer setting from 20 seconds up to 10 minutes
- Wider field of view up to 180 degree
- Wider sensing range up 8 meter forward and 6 meter either sides
- Sensitivity adjustable sensor to the size of object and range
- Flexible mounting either to wall or soft fit

- Double insulated and rated IP44
- Specially designed plastic mounting base to provide more rooms for wiring

Main Application

Suitable to use as security lighting at passage way, staircase and garage.

Materials & Finish

Use of nylon for all plastic components
Porcelain lamp holder
Aluminum Die-cast for lamp fitting

Option

Accessories and color options upon request

Quantity

Box Quantity : 1 pcs

WIRING DIAGRAM & INSTALLATION TIPS

