



TECHNICAL DATA SHEET

1600-HOTEL-S-002

HOTEL SERIES E-CARD OPERATED FLUSH



Description

A E-card switch plate is designed for ease of installation and having all the advantages and design features. These products can be quickly installed as replacements for existing switch plate or in new installations.

Features

- Breakthrough in style with quality plate finishes of pleasant curved design
- Use of high impact resistant material, flame retarding & UV stabilized polycarbonate
- Front plates with high gloss finishing offering long lasting protection
- Switch mechanism constructed in compact & simple manner with minimum parts
- Large terminal faces to provide maximum installer versatility even in confined spaces

Main Application

Suitable for switching fluorescent or inductive loads at commercial areas such as at hotel rooms & etc

Materials & Finish

- Use of polycarbonate for all plastic components
- Brass & Copper for all conductivity components
- All contact point is silver welded for best performance

Option

Accessories and color options upon request

Quantity

Box Quantity : 10 pcs
Outer Box : 100 pcs

TECHNICAL SPECIFICATION

Electrical

Voltage rating: 250V a.c.

Unit	Rating	Terminal capacity
10AX switches	10AX	4 x 1.5mm ²

Physical

Ambient operating temperature: -5°C to +40°C

Max. installation altitude: 2000 meters

Dimension

Dimension	L	X	W	X	H	
Plate Size	:	86	x	86	x	18.5mm
Mounting Centres	:	60.3mm				

NOTE:

Maximum load of switches is 16Amp Resistive

WIRING DIAGRAM

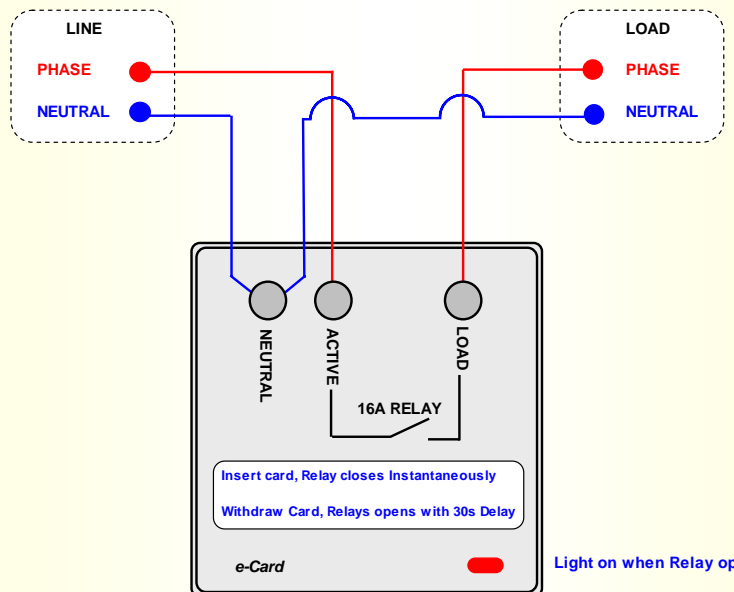

PRODUCT RANGE

Description

1 Gang 1 Way Single Pole with Neon & 2 spare switch module apertures & key-card

CAT No.

1686eC

Key-card

1686NKC